

AVERY DENNISON MARKETING SPECIFICATION

HISTORY

REV.	DATE	DESCRIPTION
A	10.15.18	RELEASED

THE SUBJECT MATTER DISCLOSED HEREIN EMBODIES PROPRIETARY INFORMATION WHICH IS THE CONFIDENTIAL PROPERTY OF THE AVERY DENNISON CO. NONE OF WHICH SHALL BE COPIED, REPRODUCED, DISCLOSED TO OTHERS, PUBLISHED OR USED IN WHOLE OR IN PART, FOR ANY PURPOSE OTHER THAN THAT FOR WHICH IT IS BEING MADE AVAILABLE WITHOUT THE EXPRESS ADVANCE WRITTEN PERMISSION OF A DULY AUTHORIZED AGENT OF THE COMPANY. THIS DOCUMENT IS THE PROPERTY OF THE AVERY DENNISON CO. AND IS TO BE RETURNED TO THE COMPANY ON DEMAND.

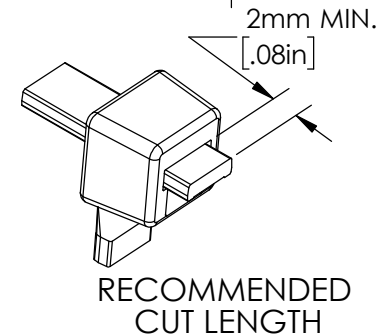
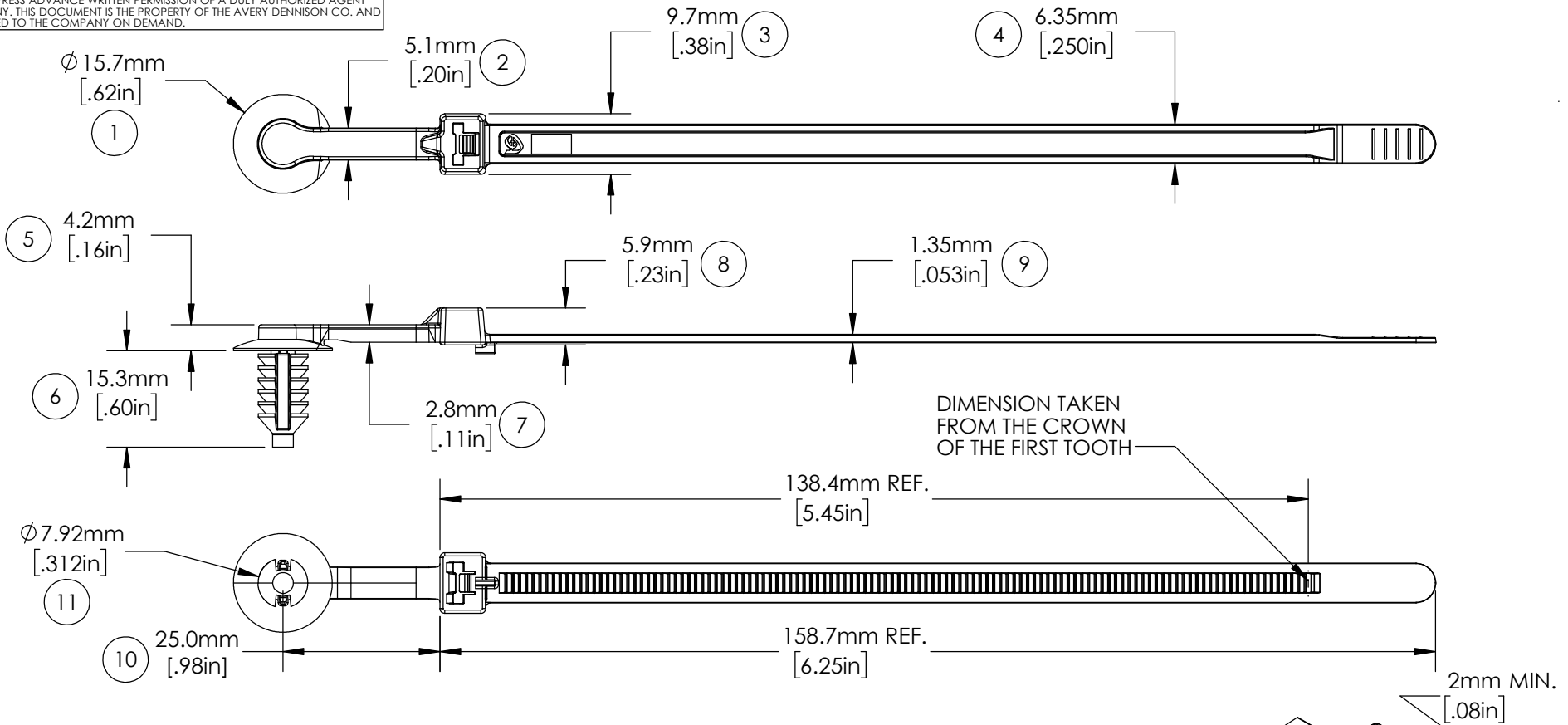

NOTES:
1. SPECIAL CHARACTERISTICS ARE NOTED BY A TRIANGLE (Δ)

12	△ FLAMMABILITY RATING:	HB RATED PER FMVSS302
13	△ TENSILE STRENGTH:	50 LBF / 222.4N MIN.
	MOUNTING:	Ø 6.60mm ± 0.25mm HOLE AND 6.35mm HEX HOLE. PANEL THICKNESS OF 0.7mm TO 7.0mm
	INSERTION FORCE:	15lbs/ 66.7N
	EXTRACTION FORCE:	45lbs/ 200.2N
	TEMPERATURE RANGE:	-40 °F (-40 °C) TO 257 °F (125 °C) CONTINUOUS
	WEIGHT:	2.1g
	BUNDLE DIAMETER:	Ø 1/16" [1.6mm] TO Ø 1- 1/2" [38.1mm]
	INSTALLATION TOOL:	12001 - HAND TOOL 12500 - PNEUMATIC TOOL
	TOOL TENSION SETTING:	6 - 8
	PACKAGING:	1000/BAG, 5 BAGS/MASTER

APPROVALS:	ENG. APPR.	<i>Daniel Gilbertson</i>	10.15.18
	Q.A. APPR.	<i>Rick Estano</i>	10.15.18
SPECIFIED TOLERANCES		MATERIAL	DESCRIPTION
	INCHES	mm	25mm LIFT OFFSET TIE - STD, HS
	.XX ± .03	.X ± .7	NYLON 6/6, HEAT STABILIZED
	.XXX ± .01	.XX ± .25	COLOR BLACK
	ANGULAR: ± 2°		STOCK NO. 20193-0



FASTENER DIVISION
FITCHBURG, MA 01420 U.S.A.
TEL. 1-800-225-5913
FAX. 978-353-8157

REV.
A